

Ako som sa (ne)stretol s umením



Sada
motivačných kariet

Karty slúžia:

- ako námety do diskusie na všeobecné umelecko-kultúrne témy,
- na vyjadrenie pocitov a nálad počas reflexie,
- na zdieľanie zážitkov z účasti na podujatiach alebo vzdelávaní.

Tipy na ďalšie aktivity s kartami:

- tvorba alternatívnych názvov obrázku,
- originálne výtvarné, hudobné, divadelné a filmové rozpracovanie tém, ktoré obrázok načrtáva,
- generovanie pojmov, ktoré s obrázkom súvisia,
- hľadanie medzipredmetových vzťahov daných obrazových situácií,
- spájanie rôznych obrázkov na základe istej súvislosti,
- tvorba dialógov v oživených obrazoch,
- rozohranie príbehu obrázka v rolovej hre,
- spracovanie obrázka do myšlienkovej mapy,
- triedenie, priraďovanie obrázkov podľa zvoleného kľúča,
- východisko k písaniu príbehu, úvahy či eseje,
- môžete si ich len tak vystaviť a tešiť sa z umenia -
- alebo máte ešte lepší nápad?

**Prajeme veľa zážitkov pri práci s touto
originálnou obrázkovou sadou!**

Ako som sa (ne)stretol s umením

Sada motivačných kariet

Autorské obrázky výtvarníčky Júlie Madzikovej možno využiť v činnosti sprievodcov umením ako úvodnú motiváciu k rozhovorom o umení alebo ako pocitové karty na vyjadrenie nálad či zdieľanie zážitkov v rámci reflexie.

Motivačné karty predstavujú doplňujúci metodický materiál publikácie **COOLTÚRA - Sprievodca sprievodcu mladého človeka na ceste za umením** (Cenef, 2023).

Ďalšie metodické materiály pre sprievodcov mladých ľudí na ich ceste za umením sú dostupné na:

<https://touchtheculture.eu/publikacia/>

Ilustrácie: Júlia Madziková

Zostavila: Júlia Balážová

Vydalo: CENEF - Centrum pre podporu neformálneho vzdelávania

Prešov (Slovensko), 2023



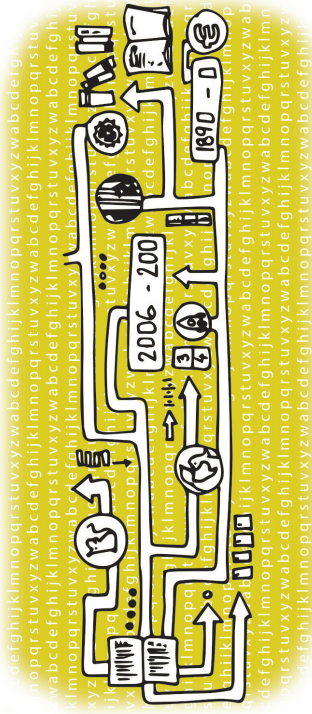



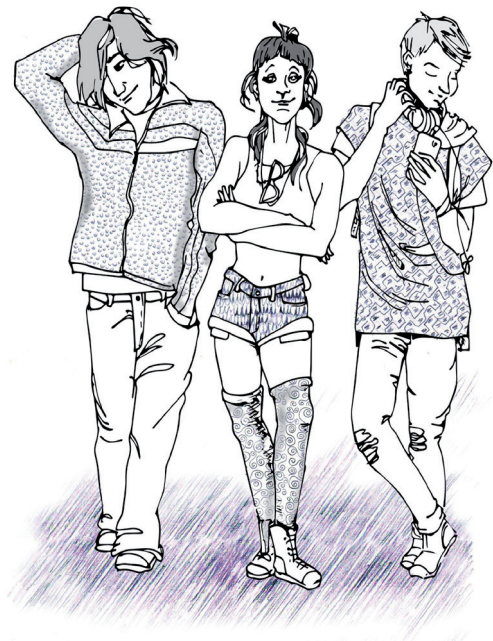



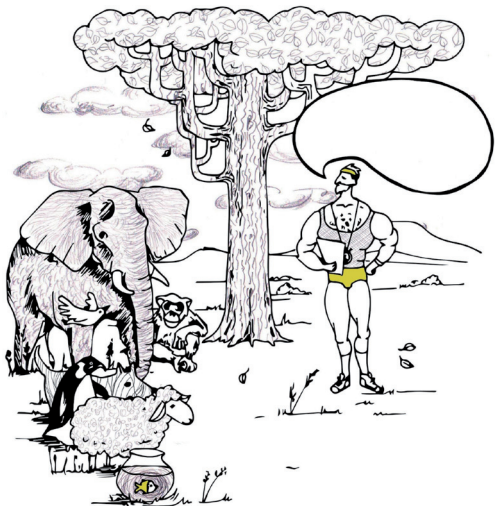



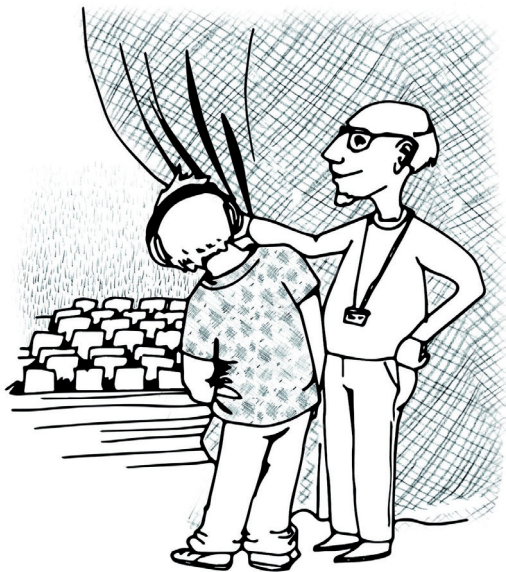



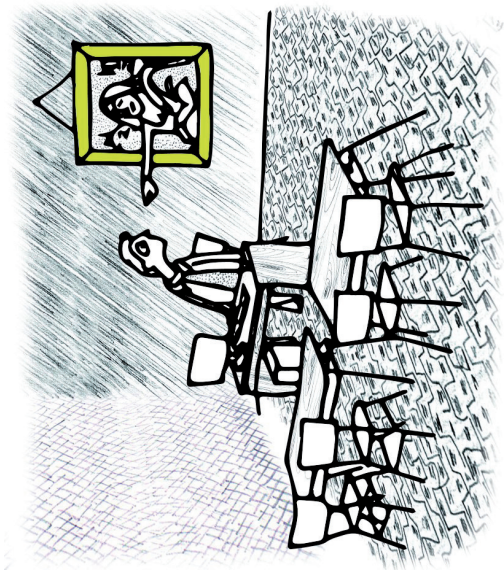

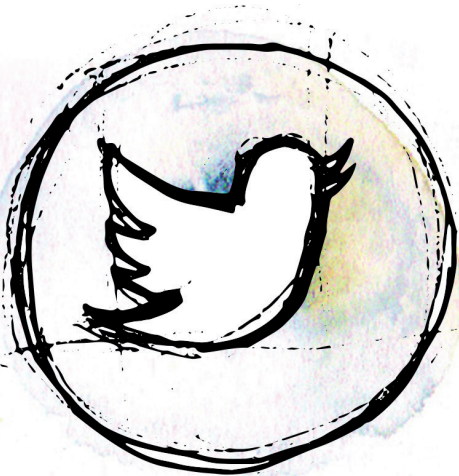

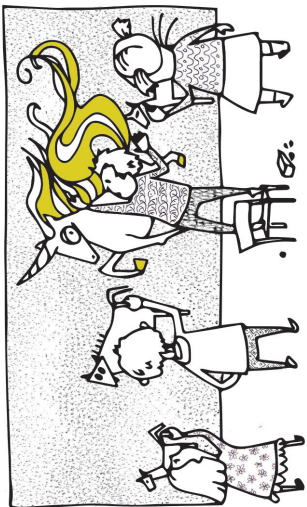
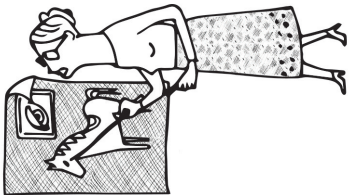



Pat
za
VA
Cena
za
CIVAR
apuca
Larid
vaz
vaz

ŠUFI
KAZA'SHA

ŠUFLIK
KAZA'SHA
Strome

erm
gu
Zrodá
poh
masur
Hosti

Zrodá
poh
masur
Hosti

Seden
šatec
BITA
NOZON

TAŠK
NAH
SADA
SADA

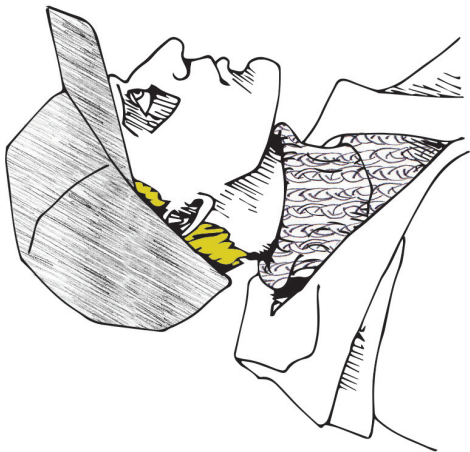

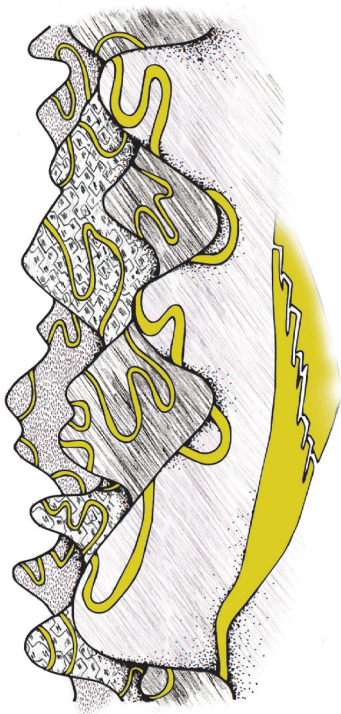





I
g u
h z D F C z i
f y X G o U C S D D I E d
i B h h i H f d U f s k i
o p o h h o k I O h i p

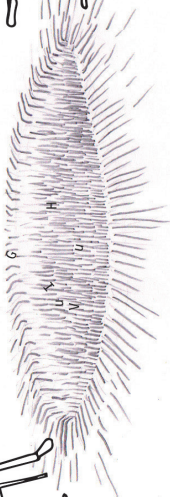

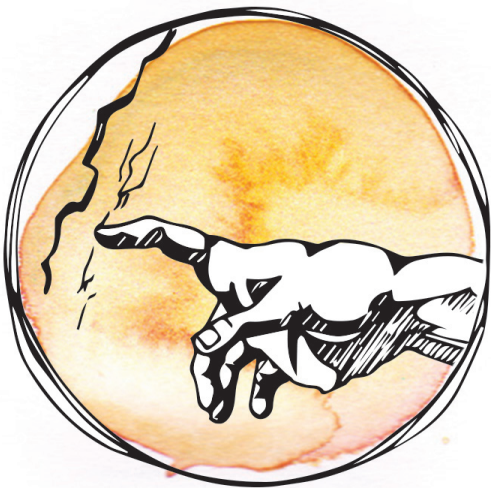

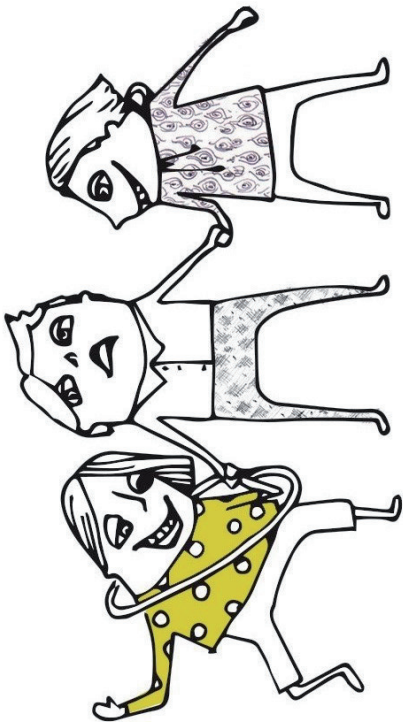

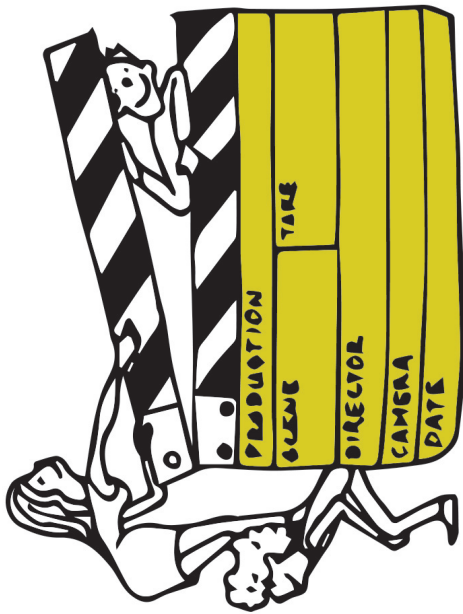

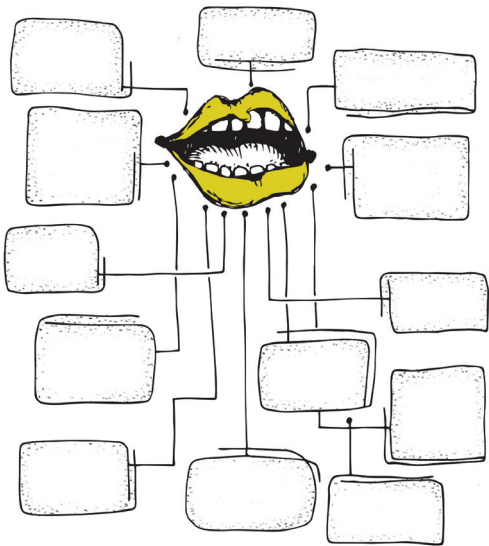

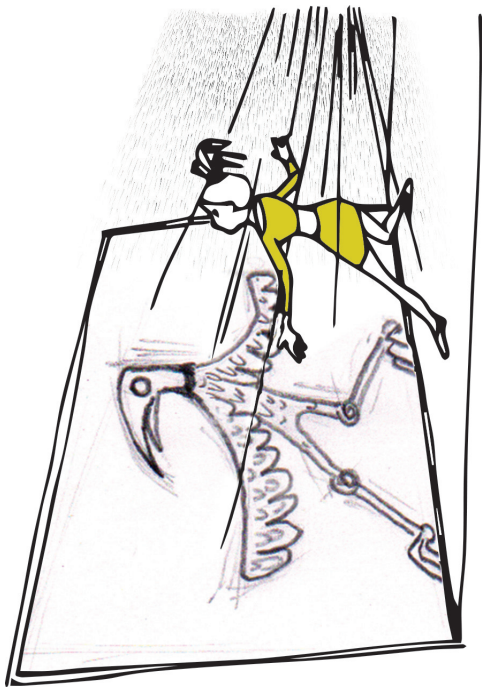









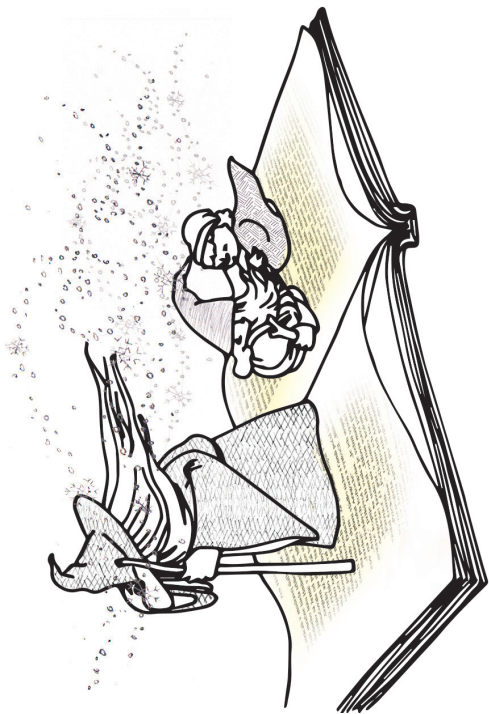





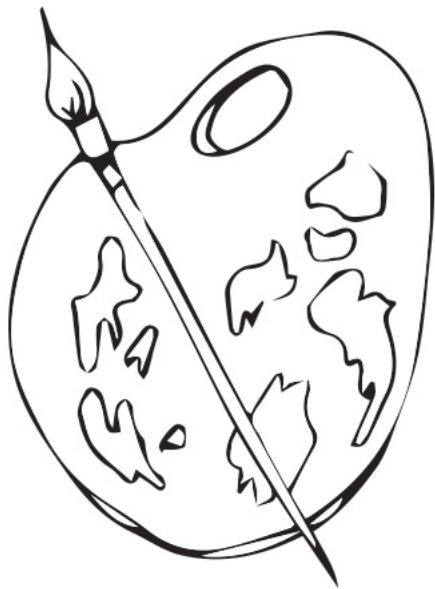

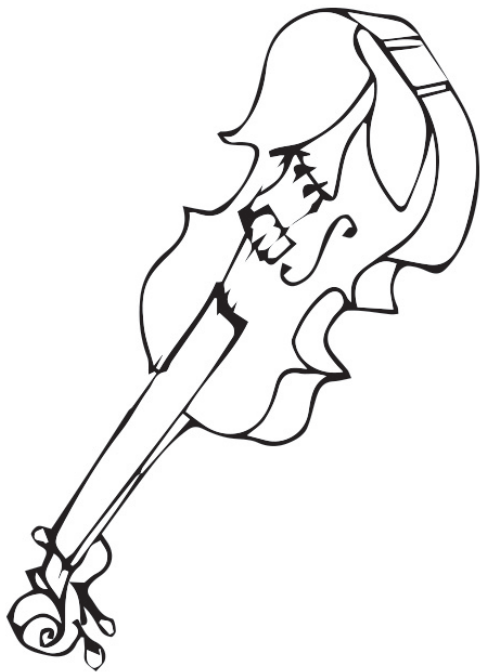













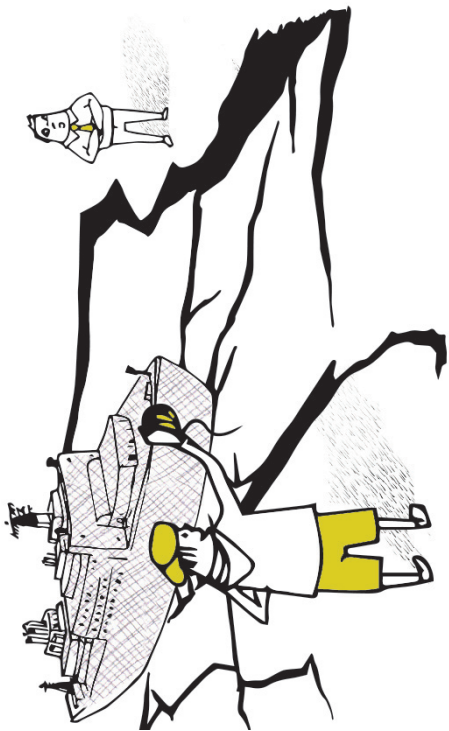

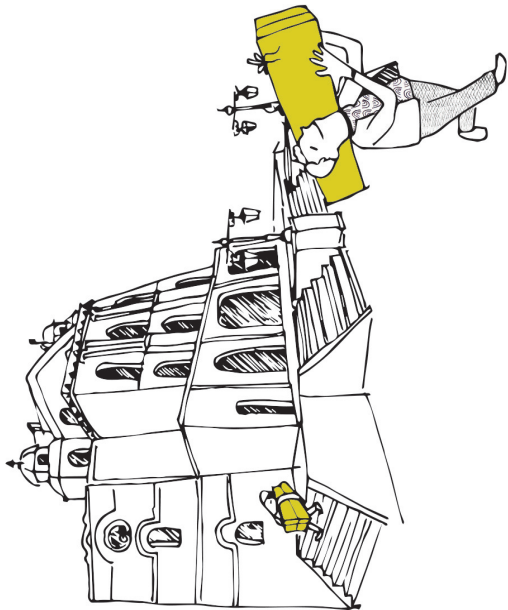



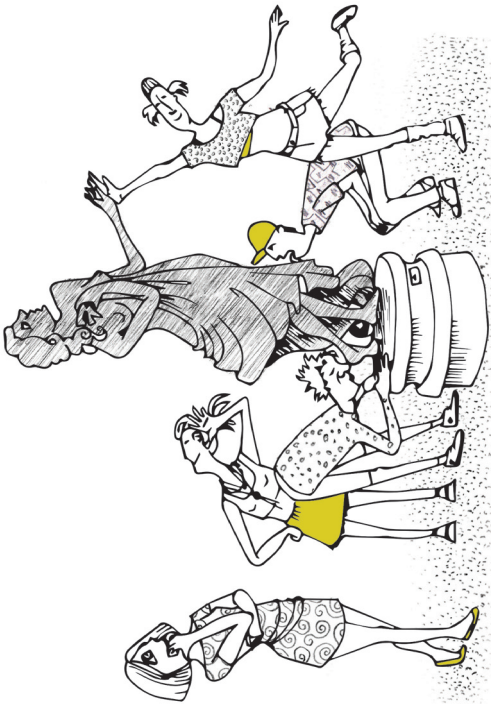

Cute

Vibe

Mood



High

CRINGE

CRINGE

CRINGE

High

Felák

Hood

LEGIT

Vibe

Hood

High

Cute

Mood

LEGIT

Mood



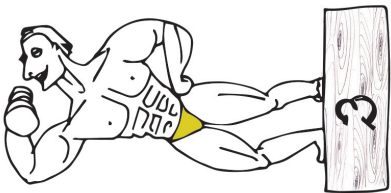
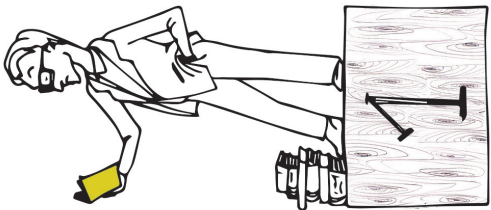
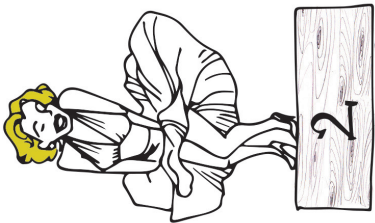

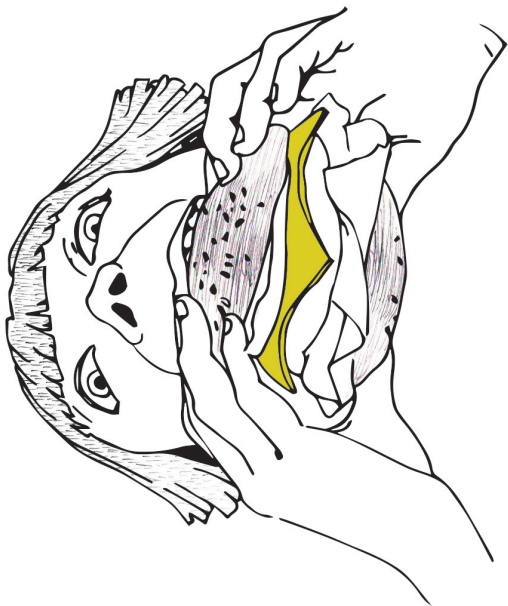



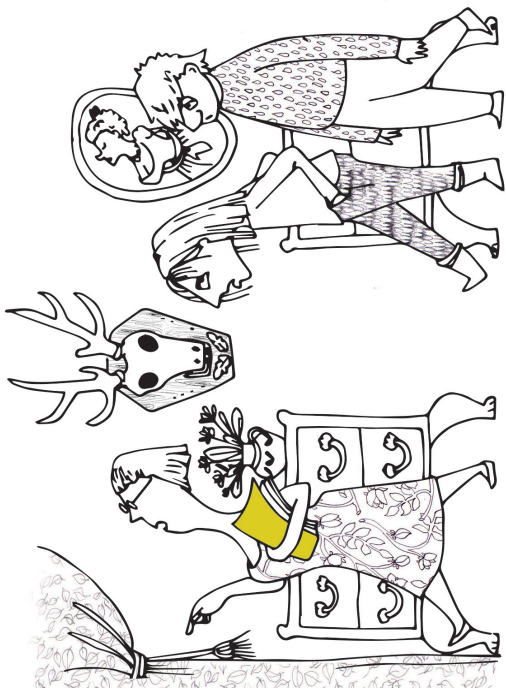

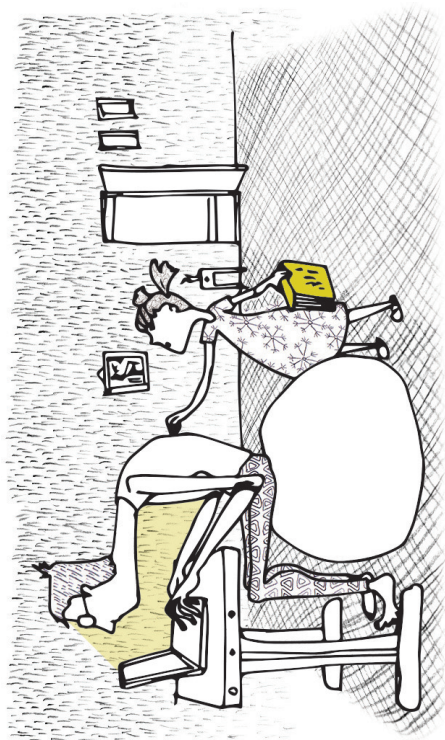







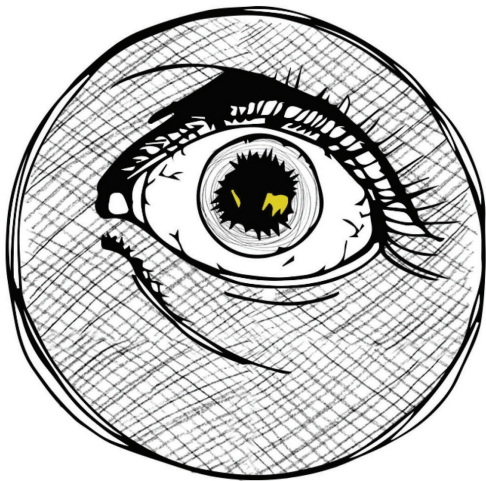



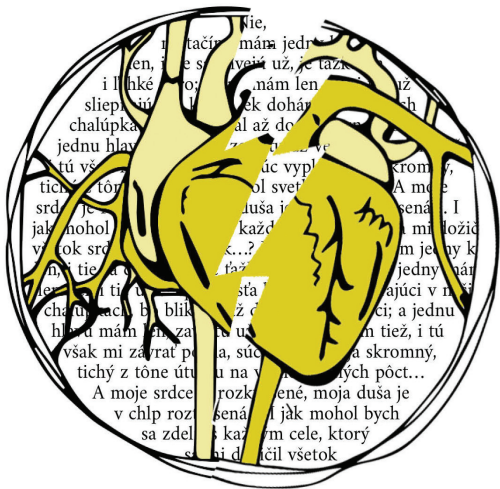

Nie,
 m... tačím... mám jedr...
 en, i... e s... aveiá už, je tazk...
 i ľhké... o;... nám len... už
 sliepi... ú... k... dohár... sh
 chalúpk... al až do...
 jednu hlav... z... ve
 tú vš... úc vypl... kromy,
 tich... tón... ol svet... A moe
 srdc... je... duša i... sená... I
 jak... mohol... každ... m... ložič
 v... tok srd... k...? m... jedny k
 n, i... tie... a... ťaž... jedny nár
 er... n... t... u... sta... ajúci v n...
 cha... u... ach... b... blik... ť... ť... ci; a jednu
 hlav... u... mám len, za... to us... m... tiež, i tú
 však mi závrat... a, súc... a skromný,
 tichý z tóne útu... u na v... ných pôct...
 A moje srdce... rozk... ené, moja duša je
 v chlp roz... sená... í jak mohol bych
 sa zdel... k... každ... m... cele, ktorý
 s... ni d... ňčil všetok



